

KAYNAK BOYUNLU FLANŞ PN 25  
WELDING NECK FLANGE PN 25  
TİP 11 / TYPE 11  
DIN 2630

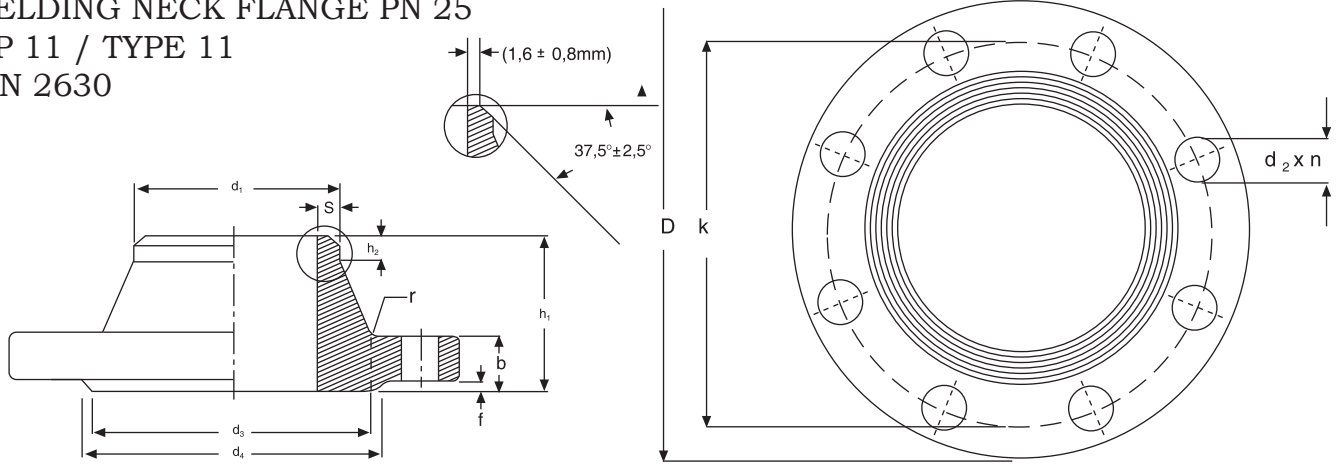

BORU / PIPE		FLANŞ/FLANGE				BOYUN / NECK				ALIN ÇIKTISI/RAISED FACE		DELİKLER/DRILLINGS		AĞIRLIK (WEIGHT)		
DN	d <sub>1</sub> EN-1092-1	D	b EN-1092-1 DIN 2501		k	h <sub>1</sub>	d <sub>3</sub>	s	R	h <sub>2</sub>	d <sub>4</sub>	f	n		SAPLAMA (SCREW)	d <sub>2</sub>
15	21,3	95	16	14	65	38	32	2,00	4	6	45	2	4	M12	14	0,75
20	26,9	105	18	16	75	40	40	2,30	4	6	58	2	4	M12	14	1,06
25	33,7	115	18	16	85	40	46	2,60	4	6	68	2	4	M12	14	1,29
32	42,4	140	18	18	100	42	56	2,60	6	6	78	2	4	M16	18	1,88
40	48,3	150	18	18	110	45	64	2,60	6	7	88	3	4	M16	18	2,33
50	60,3	165	20	20	125	48	75	2,90	6	8	102	3	4	M16	18	2,82
65	76,1	185	22	22	145	52	90	2,90	6	10	122	3	8	M16	18	3,74
80	88,9	200	24	24	160	58	105	3,20	8	12	138	3	8	M16	18	4,75
100	114,3	235	24	24	190	65	134	3,60	8	12	162	3	8	M20	22	6,52
125	139,7	270	26	26	220	68	162	4,00	8	12	188	3	8	M24	26	9,07
150	168,3	300	28	28	250	75	192	4,50	10	12	218	3	8	M24	26	11,80
200	219,1	360	30	30	310	80	244	6,30	10	16	278	3	12	M24	26	17,00
250	273	425	32	32	370	88	298	7,10	12	18	335	3	12	M27	30	24,40
300	323,9	485	34	34	430	92	352	8,00	12	18	395	4	16	M27	30	31,20
350	355,6	555	38	38	490	100	398	8,00	12	20	450	4	16	M30	33	47,20
400	406,4	620	40	40	550	110	452	8,80	12	20	505	4	16	M33	36	61,70
450	457	670	46	40	600	110	500	8,80	12	20	555	4	20	M33	36	71,90
500	508	730	48	44	660	125	558	10,00	12	20	615	4	20	M33	36	89,60
600	610	845	48	46	770	125	660	11,00	12	20	720	5	20	M36	39	104,00
700	711	960	50	48	875	125	760	12,50	12	20	820	5	24	M39	42	136,00
800	813	1085	53	50	990	135	864	14,20	12	22	930	5	24	M45	48	186,00
900	914	1185	57	54	1090	145	968	16,00	12	24	1030	5	28	M45	48	236,00
1000	1016	1320	63	58	1210	155	1070	17,50	16	24	1140	5	28	M52	56	307,00

\*Ölçüler mm'dir.

\*Dimensions are in mm.