

KAYNAK BOYUNLU FLANŞ PN 100
WELDING NECK FLANGE PN 100
TS - EN 1092 - 1
TİP 11 / TYPE 11
DIN2631

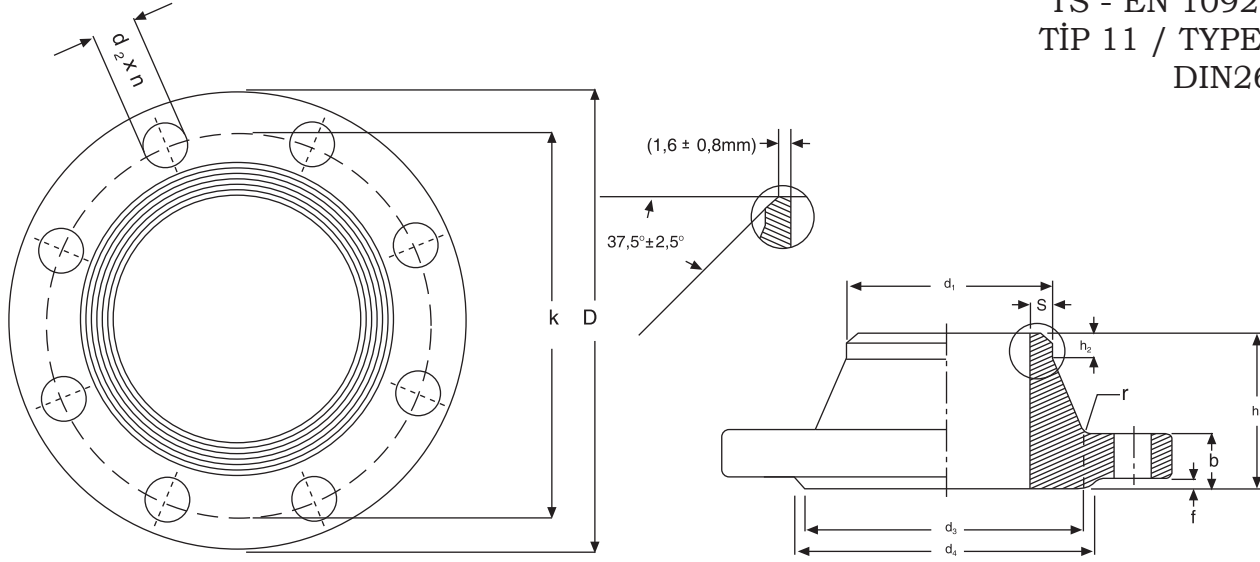

BORU / PIPE		FLANŞ / FLANGE				BOYUN / NECK				ALIN ÇIKTISI / RAISED FACE		DELİKLER / DRILLINGS			AĞIRLIK (WEIGHT)
DN	d ₁	D	b	k	h ₁	d ₃	s	R	h ₂	d ₄	f	n	SAPLAMA (SCREW)	d ₂	
15	21,3	105	20	75	45	34	2,00	4	6	45	2	4	M12	14	1,19
20	26,9	130	22	90	48	42	2,60	4	8	58	2	4	M16	18	-
25	33,7	140	24	100	58	52	2,60	4	8	68	2	4	M16	18	2,66
32	42,4	155	24	110	60	62	2,90	6	8	78	3	4	M20	22	-
40	48,3	170	26	125	62	70	2,90	6	10	88	3	4	M20	22	4,09
50	60,3	195	28	145	68	90	3,20	6	10	102	3	4	M24	26	5,98
65	76,1	220	30	170	76	108	3,60	6	12	122	3	8	M24	26	7,91
80	88,9	230	32	180	78	120	4,00	8	12	138	3	8	M24	26	8,95
100	114,3	265	36	210	90	150	5,00	8	12	162	3	8	M27	30	13,70
125	139,7	315	40	250	105	180	6,30	8	12	188	3	8	M30	33	22,70
150	168,3	355	44	290	115	210	7,10	10	12	218	3	12	M30	33	30,20
200	219,1	430	52	360	130	278	10,00	10	16	285	3	12	M33	36	52,80
250	273	505	60	430	157	340	12,50	12	18	345	3	12	M36	39	81,40
300	323,9	585	68	500	170	400	14,20	12	18	410	4	16	M39	42	122,00
350	355,6	655	74	560	189	460	16,00	12	20	465	4	16	M45	48	165,00

*Ölçüler mm'dir.

*Dimensions are in mm.